

Product Summary

$V_{(BR)DSS}$	$R_{DS(on)TYP}$	I_D
30V	1.4m Ω @10V	120A
	1.9m Ω @4.5V	

Feature

- Split Gate Trench Technology
- Low $R_{DS(ON)}$
- Low Gate Charge
- Low Gate Resistance
- 100% UIS Tested

Application

- Power Switching Application
- DC/DC Converter

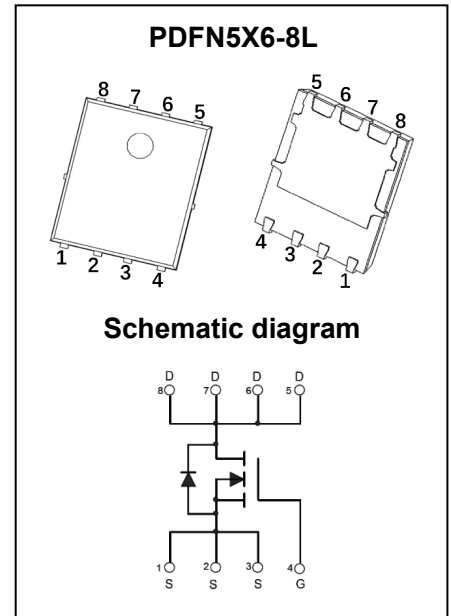

Package Marking and Ordering Information

Part Number	Package	Marking	Packing	Reel Size	Tape Width	Qty
GPT017N03LNC	PDFN5X6-8L	T017N03L	Reel & Tape	330mm	12mm	5000pcs

ABSOLUTE MAXIMUM RATINGS ($T_A = 25^\circ\text{C}$ unless otherwise noted)

Parameter	Symbol	Value	Unit
Drain-Source Voltage	V_{DS}	30	V
Gate-Source Voltage	V_{GS}	± 16	V
Continuous Drain Current ¹	$T_C = 25^\circ\text{C}$	I_D	120
	$T_C = 100^\circ\text{C}$	I_D	74
Pulsed Drain Current ²	I_{DM}	480	A
Single Pulsed Avalanche Current ³	I_{AS}	36	A
Single Pulsed Avalanche Energy ³	E_{AS}	324	mJ
Power Dissipation ⁵	$T_C = 25^\circ\text{C}$	P_D	78
Thermal Resistance from Junction to Ambient ⁶	$R_{\theta JA}$	50	$^\circ\text{C/W}$
Thermal Resistance from Junction to Case	$R_{\theta JC}$	1.6	$^\circ\text{C/W}$
Junction Temperature	T_J	150	$^\circ\text{C}$
Storage Temperature	T_{STG}	-55~ +150	$^\circ\text{C}$

MOSFET ELECTRICAL CHARACTERISTICS ($T_A = 25^\circ\text{C}$ unless otherwise noted)

Parameter	Symbol	Test Condition	Min	Type	Max	Unit
Off Characteristics						
Drain-Source Breakdown Voltage	$V_{(BR)DSS}$	$V_{GS} = 0V, I_D = 250\mu A$	30			V
Zero Gate Voltage Drain Current	I_{DSS}	$V_{DS} = 30V, V_{GS} = 0V$			1	μA
Gate-Body Leakage Current	I_{GSS}	$V_{GS} = \pm 16V, V_{DS} = 0V$			± 100	nA
On Characteristics⁴						
Gate Threshold Voltage	$V_{GS(th)}$	$V_{DS} = V_{GS}, I_D = 250\mu A$	1.0	1.5	2.5	V
Drain-Source On-Resistance	$R_{DS(on)}$	$V_{GS} = 10V, I_D = 20A$		1.4	1.9	m Ω
		$V_{GS} = 4.5V, I_D = 20A$		1.9	2.5	
Dynamic Characteristics						
Input Capacitance	C_{iss}	$V_{DS} = 15V, V_{GS} = 0V, f = 1MHz$		3371		pF
Output Capacitance	C_{oss}			758		
Reverse Transfer Capacitance	C_{rss}			112		
Gate Resistance	R_g	$V_{DS} = 0V, V_{GS} = 0V, f = 1MHz$		4.9		Ω
Switching Characteristics						
Total Gate Charge	Q_g	$V_{DS} = 30V, V_{GS} = 10V, I_D = 20A$		64		nC
Gate-Source Charge	Q_{gs}			9		
Gate-Drain Charge	Q_{gd}			11		
Turn-On Delay Time	$t_{d(on)}$	$V_{DD} = 15V, V_{GS} = 10V, R_L = 0.75\Omega, R_G = 3\Omega$		10		ns
Turn-On Rise Time	t_r			6		
Turn-Off Delay Time	$t_{d(off)}$			83		
Turn-Off Fall Time	t_f			20		
Source-Drain Diode Characteristics						
Diode Forward Voltage ⁴	V_{SD}	$V_{GS} = 0V, I_S = 20A$			1.2	V

Notes:

1. The maximum current rating is limited by package. And device mounted on a large heatsink.
2. Pulse Test: Pulse Width $\leq 10\mu s$, duty cycle $\leq 1\%$.
3. E_{AS} condition: $V_{DD} = 25V, V_{GS} = 10V, L = 0.5mH, R_G = 25\Omega$ Starting $T_J = 25^\circ\text{C}$.
4. Pulse Test: Pulse Width $\leq 300\mu s$, duty cycle $\leq 2\%$.
5. The power dissipation P_D is limited by $T_{J(MAX)} = 150^\circ\text{C}$. And device mounted on a large heatsink.
6. Device mounted on $1in^2$ FR-4 board with 2oz. Copper, in a still air environment with $T_A = 25^\circ\text{C}$.

Typical Characteristics

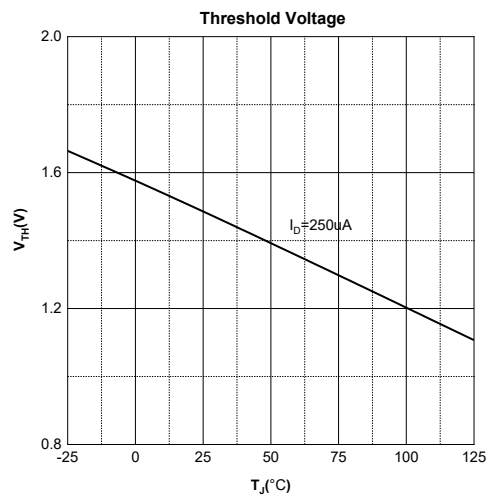
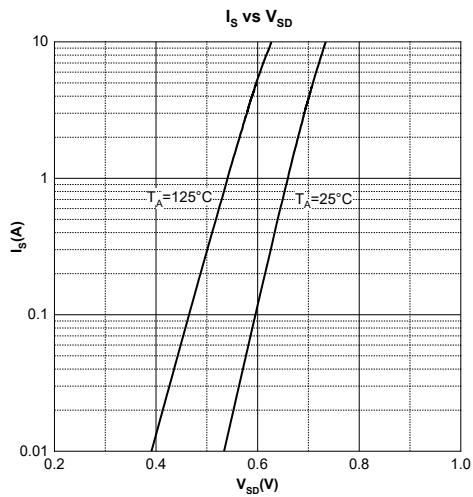
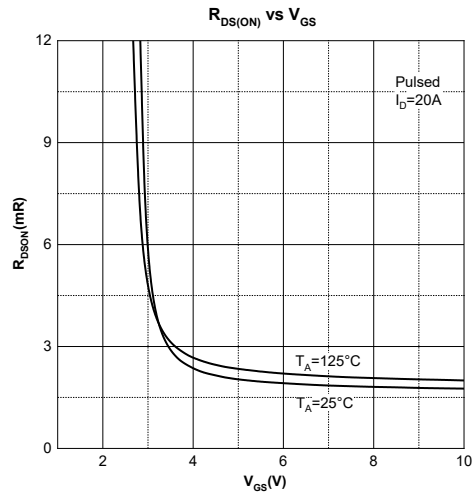
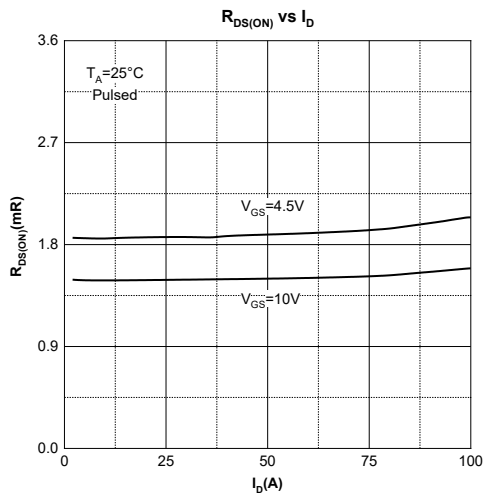
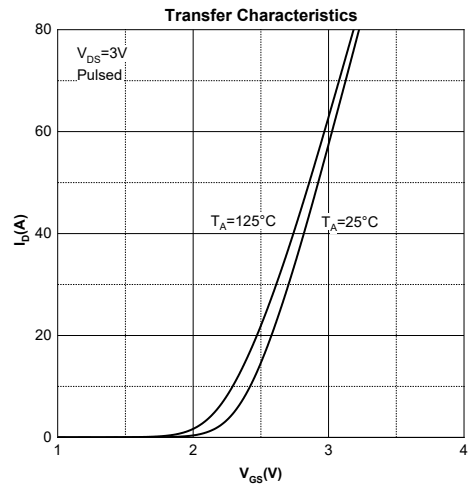
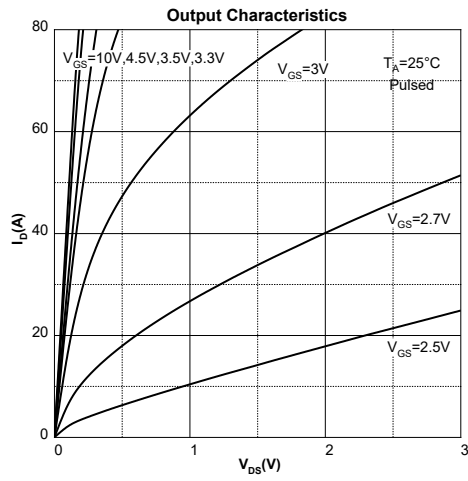

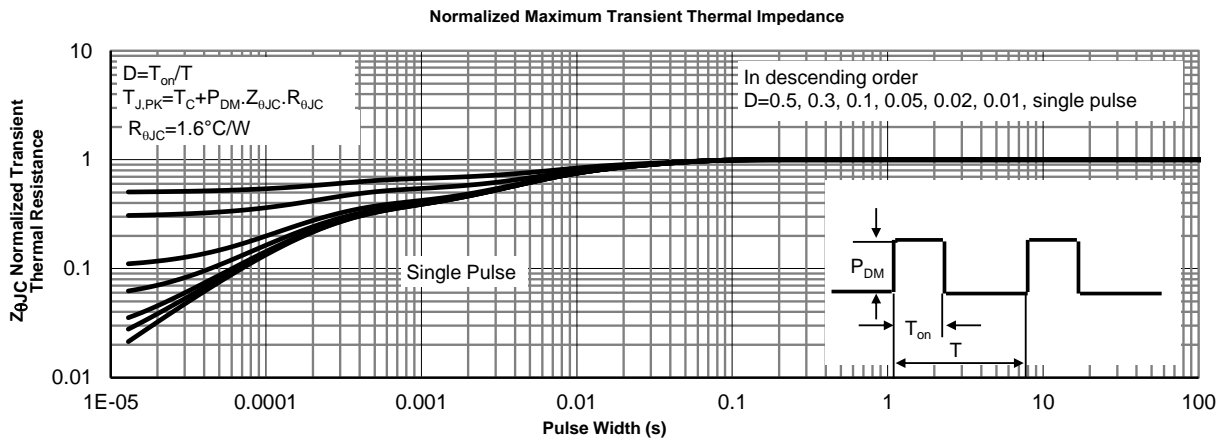
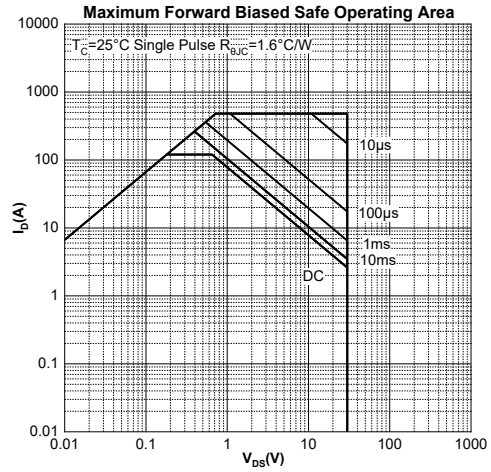
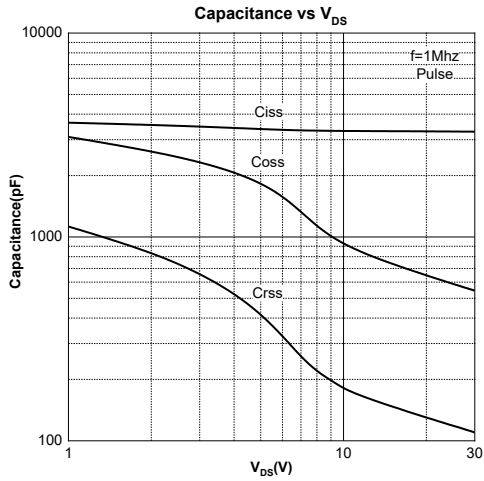

Gate Charge Test Circuit & Waveform

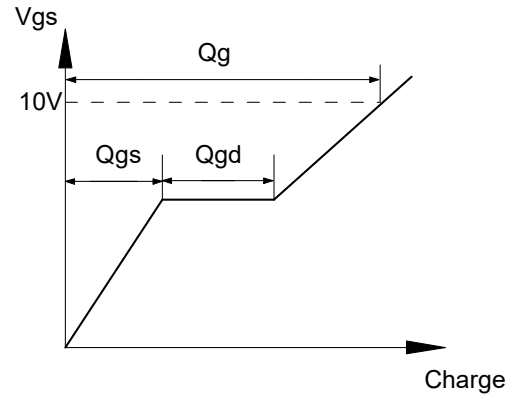
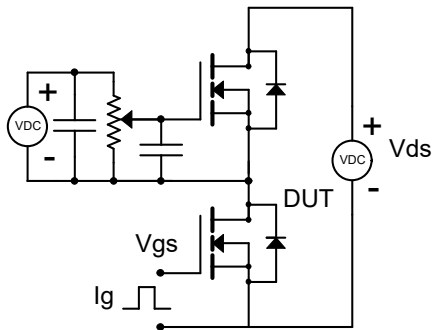

Resistive Switching Test Circuit & Waveform

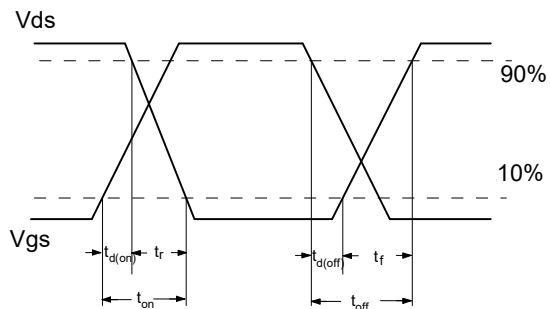
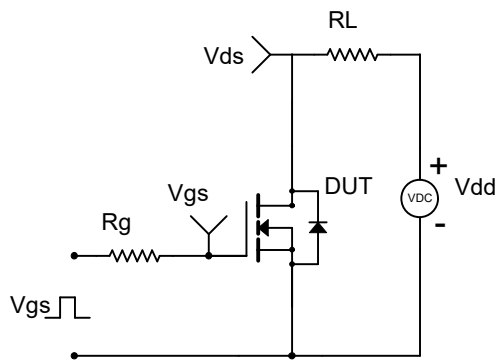

Unclamped Inductive Switching (UIS) Test Circuit & Waveforms

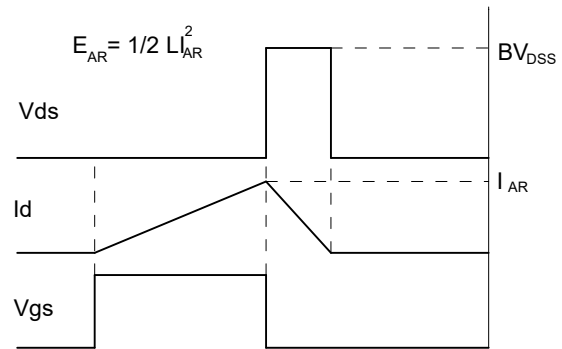
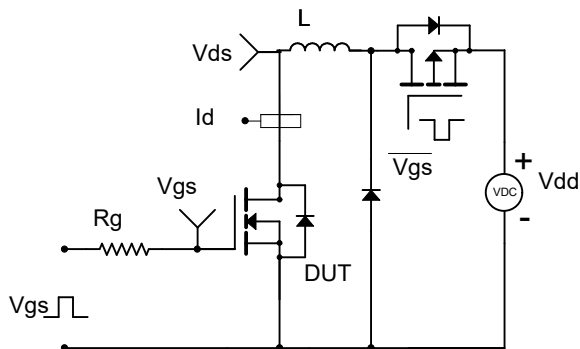

PDFN5X6-8L Package Information

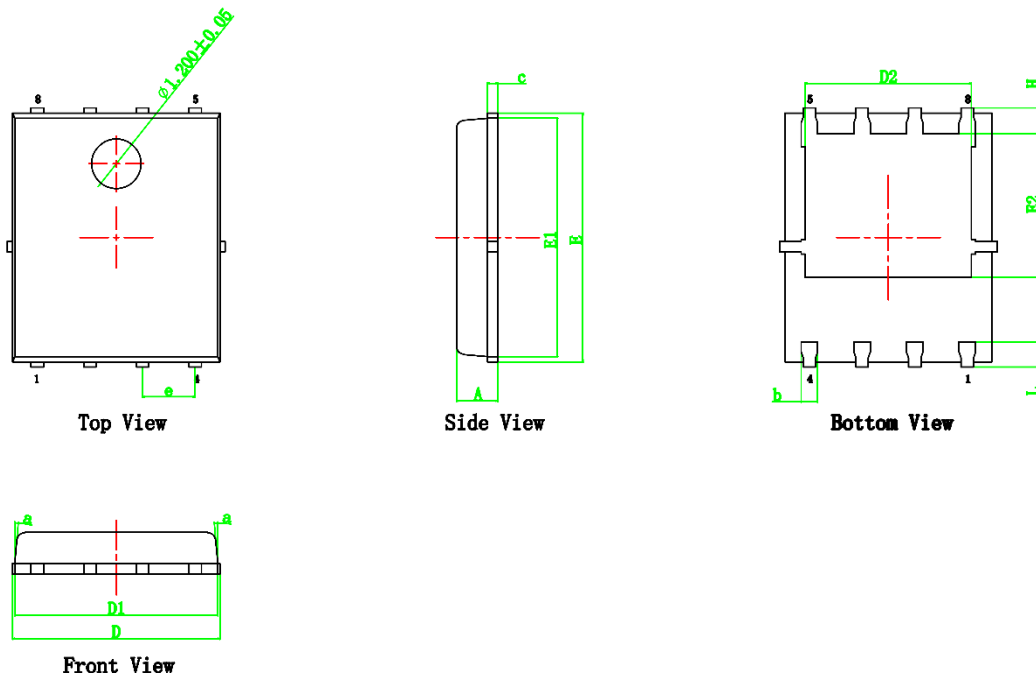

Symbol	Dimensions In Millimeters		Dimensions In Inches	
	Min.	Max.	Min.	Max.
A	0.900	1.100	0.035	0.043
b	0.330	0.510	0.013	0.020
c	0.200	0.300	0.008	0.012
D	4.820	5.220	0.190	0.206
D2	3.910	4.110	0.154	0.162
E	5.900	6.100	0.232	0.240
E1	5.700	5.800	0.224	0.228
E2	3.370	3.570	0.133	0.141
e	1.270REF		0.050REF	
H	0.520	0.720	0.020	0.028
D1	4.800	5.000	0.189	0.197
L	0.510	0.710	0.020	0.028
a	0°	10°	0°	10°

Attention:

- GreenPower Electronics reserves the right to improve product design function and reliability without notice.
- Any and all semiconductor products have certain probability to fail or malfunction, which may result in personal injury, death or property damage. Customer are solely responsible for providing adequate safe measures when design their systems.
- GreenPower Electronics products belong to consumer electronics or other civilian electronic products.